



DREAM BIG PACK SMALL

TIWAL 2
Owner's manual



TECHNICAL SPECIFICATIONS

TIWAL 2



BOAT TYPE

Dinghy

DESIGN CATEGORY

D*

LENGTH OF THE HULL

9' 2"

WIDTH OF THE HULL

4' 11"

TOTAL WEIGHT

88 lbs

MAX. ENGINE POWER

0 cv

MAX. NUMBER OF PASSENGERS

1 adult and 1 child

MAX. LOAD (PASSENGERS + LUGGAGE)

330 lbs

SAIL SURFACES AREA

60 ft²

MANUFACTURER

TIWAL

ID NUMBER

The CIN (Craft Identification Number) or HIN (Hull Identification Number) is registered on the aft part of the inflatable hull under the transom.

United States: HIN starting with TIW...

* Category D: Designed for voyages on sheltered coastal waters, small bays, small lakes, rivers and canals where conditions up to wind force 4 with and significant wave heights up to 18 inches.

You are the owner of a TIWAL 2 dinghy made by TIWAL. This manual will advise you on how to find both enjoyment and safety in navigation. Inside you will find technical specifications, assembly instructions, maneuvers and recommendations for maintenance.

If the TIWAL 2 is your first dinghy or one that you aren't accustomed to, we recommend that, at first, you familiarise yourself with its operation in calm weather conditions. Get in touch with your local sailing clubs or schools for advice regarding possible instruction.

READ THE MANUAL IN DETAIL BEFORE USING THE TIWAL 2 TO FAMILIARISE YOURSELF WITH IT'S OPERATION AND HANDLING.

Make sure that prevailing wind and sea conditions are suitable for the boat's design category, and that you and your crew are able to navigate the boat in these conditions.

This owner's manual is not a detailed guide for maintenance and repair. If you are experiencing difficulties, please get in touch with the manufacturer or a representative.

Always seek out the services of an experienced professional for maintenance and whenever fitting accessories or

making modifications. All modifications that could impact the safety characteristics must be evaluated, executed and documented by competent professionals. TIWAL SAS cannot be held liable for modifications that are not approved by the manufacturer. Certain countries require a permit or authorization for navigation or require that specific rules be followed.

Always perform the suggested maintenance on your boat and take into account that wear and tear will result over time or, as the case may be, from frequent or inappropriate use. Any boat (however sturdy) can be severely damaged if it is subject to inappropriate use. This is incompatible with safe navigation.

Always adjust the boat's speed and direction to prevailing conditions. On board, the crew must have access to certain safety equipment (life-vests, etc.) that is suited to the type of boat, the weather conditions, etc. Such safety equipment is legally required in certain countries. The crew must be familiar with the use of this equipment and with emergency safety maneuvers (man overboard, towing, etc.); regular training sessions are available through local sailing clubs and schools.

PLEASE KEEP THIS MANUAL AND GIVE IT TO THE NEW OWNER IF YOU CHOOSE TO SELL THE BOAT

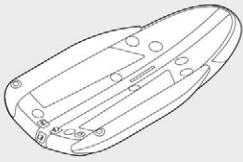

PVC HULL
2HULL02

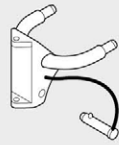

TRANSOM
1TRAN02
LOCKING PIN
2SPIN02

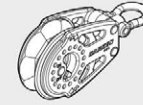

RATCHET BLOCK
2BLOC01

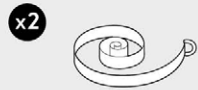

WEBBING STRAP
2WEST01



RUDDER BLADE
2RUDD01

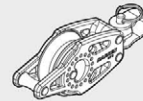

FORWARD BOOM BLOCK WITH BECKET
2BLOC03

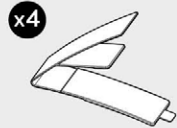

HOOK AND LOOP STRAP
2VELC01



RUDDER CASTING
2CAST01

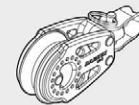

AFT BOOM BLOCK
2BLOC04



HIGH PRESSURE HAND PUMP
2HPHP01

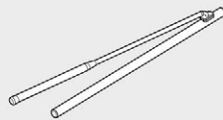

TILLER
2TILL03
EXTENSION TILLER
2STIC02

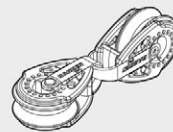

TRAVELER BLOCK
2BLOC02

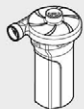

ELECTRIC PUMP
2LPEP01



DAGGERBOARD
1DAGG01

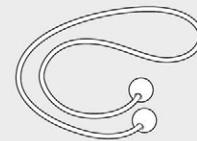

TRAVELER ROPE
2ROP601
+ BALLS
2TBAL01



CARRY BAGS
BIG 2BAGY02
SMALL 2BAGY03

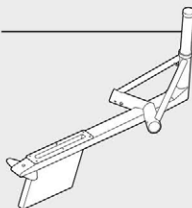

CENTRAL PIECE
1CPIE02
+ BUNGEE 2SAND601
+ TUBE 2TUBE01

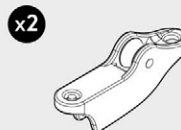

CLAM CLEAT
2CLCL01

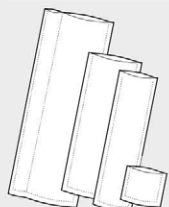

PROTECTIVE COVER
XL 2PCOV05
L 2PCOV01
M (x2) 2PCOV03
S 2PCOV02

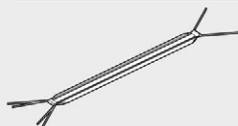

TOE STRAP
2TSTR01
+ BUNGEE 2SAND601
+ ROPE 2ROP601

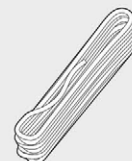

LINES
CUNNINGHAM (1m) 2ROP601
VANG (2.50m) 2ROP601
MAINSHEET (9m) 1SHEE01

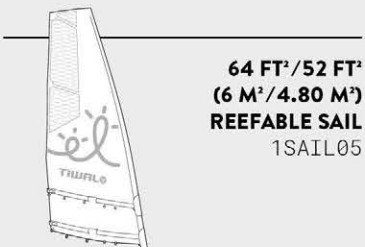
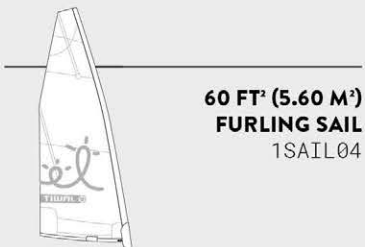
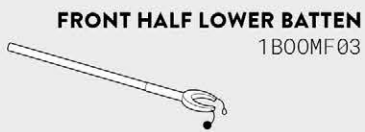
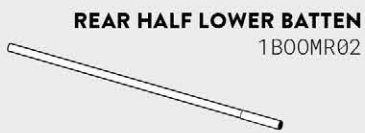
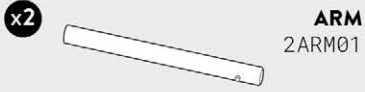

LARGE BAG

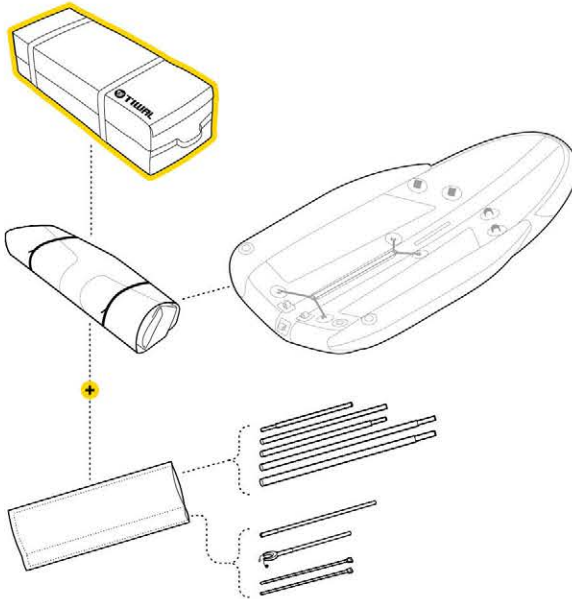

SMALL BAG

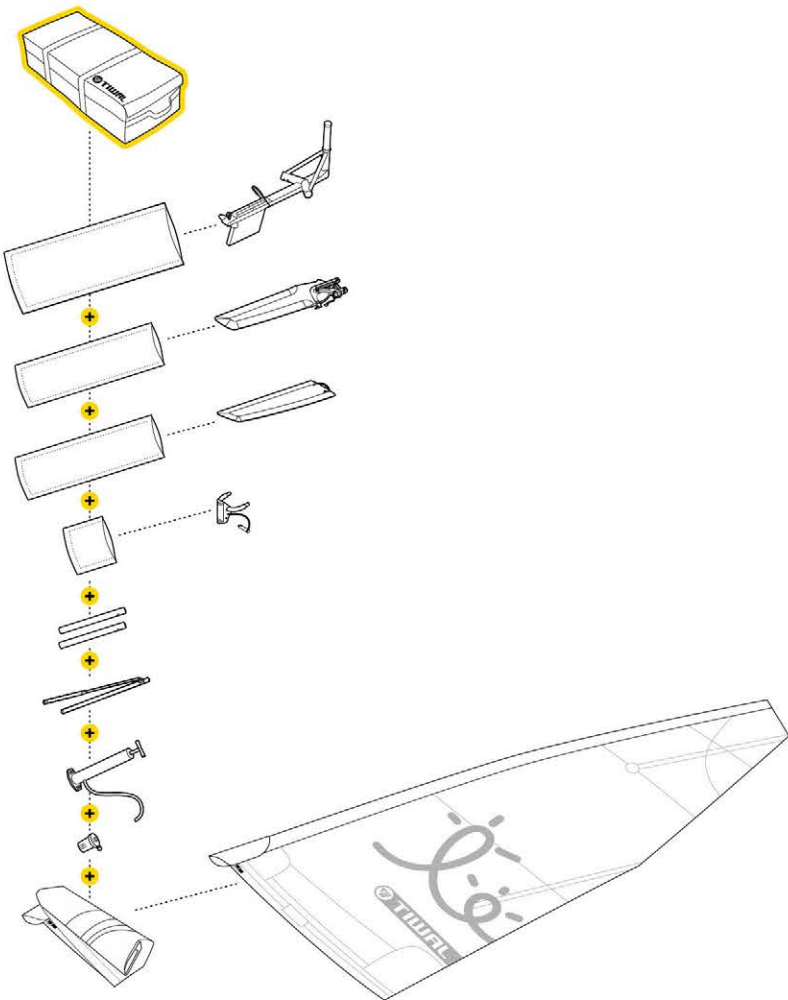

ASSEMBLY

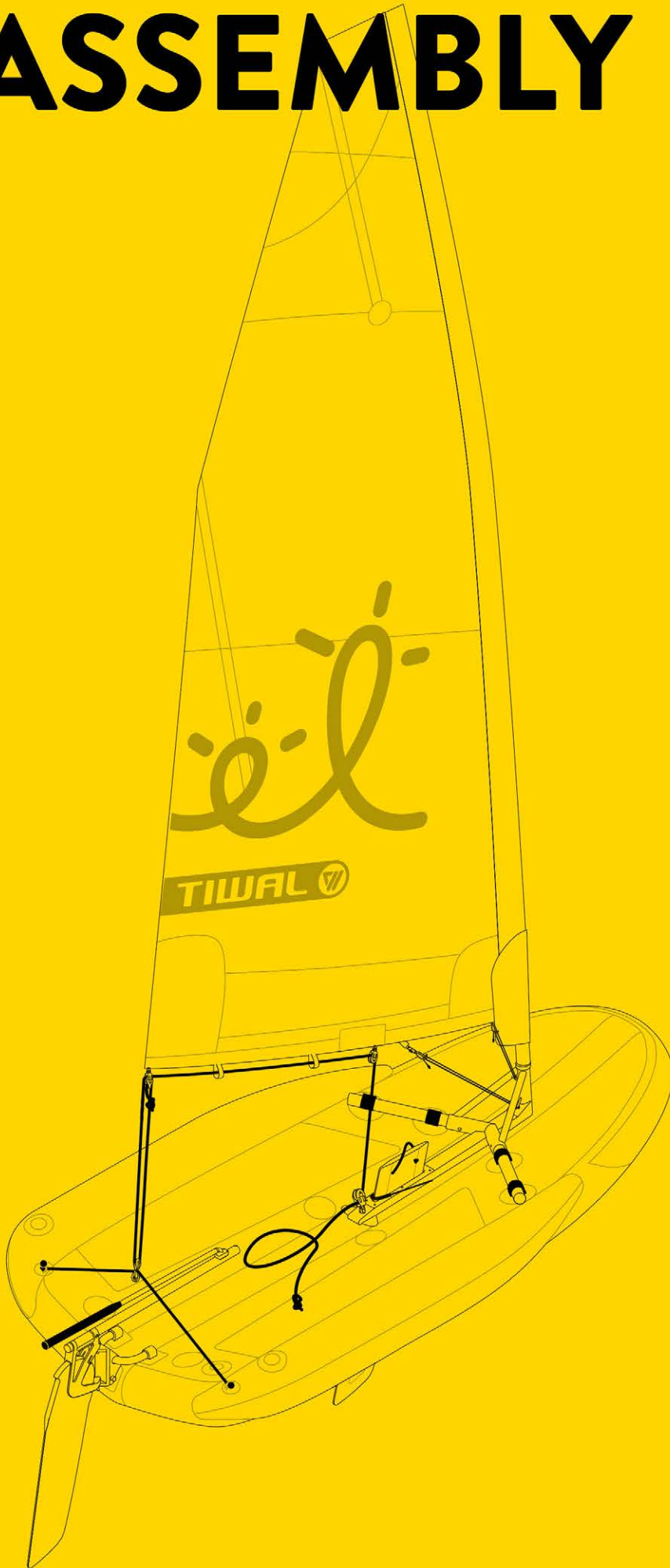

TIWAL 

1

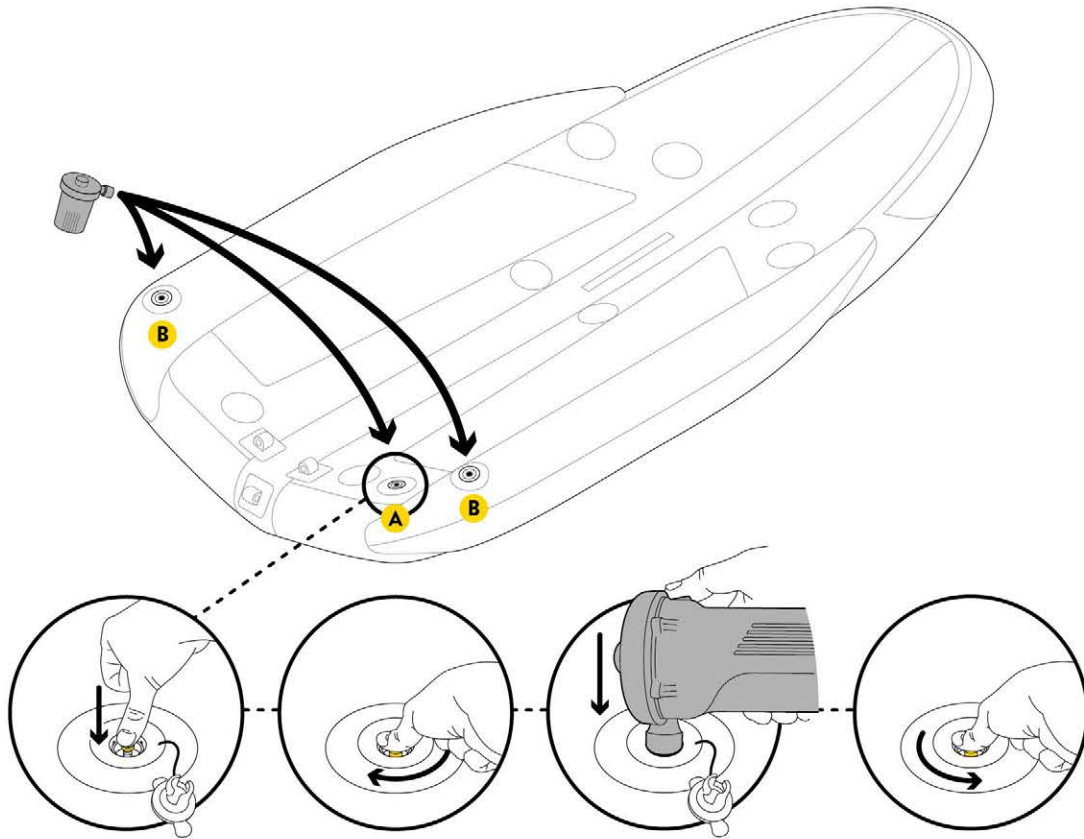

Roll out the hull on a surface free from debris that could cause any damage. Inflate the hull with the electric pump until it starts taking shape without being pressurized.
Pression <0,1 psi.

2

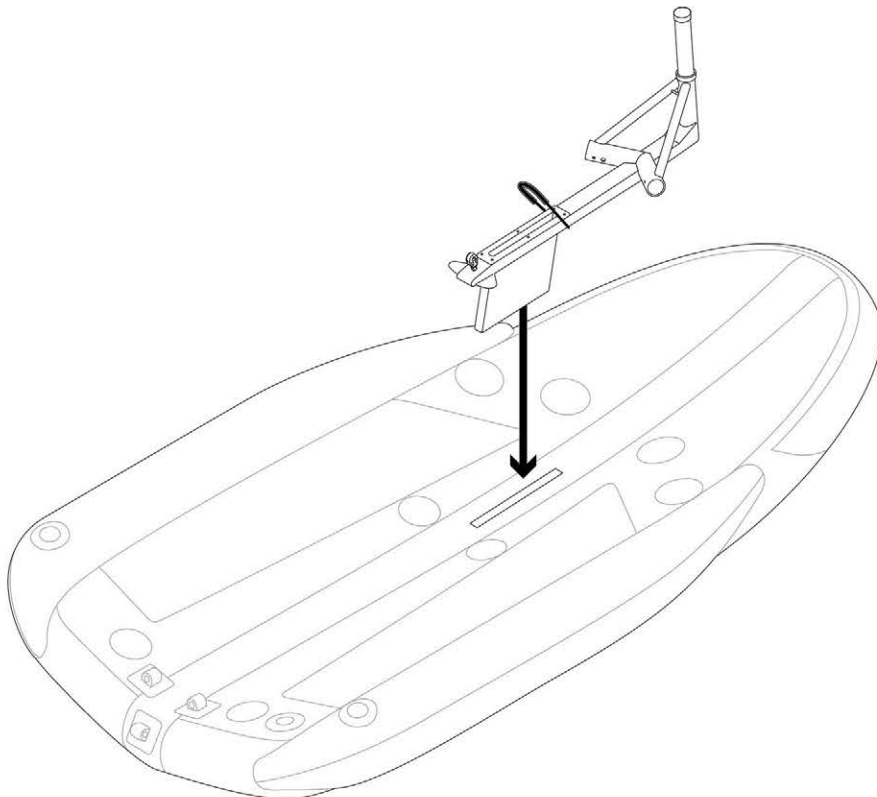

3

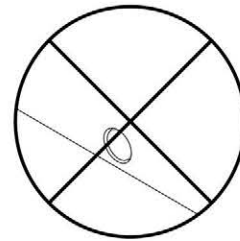
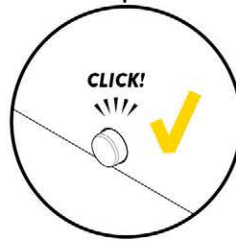
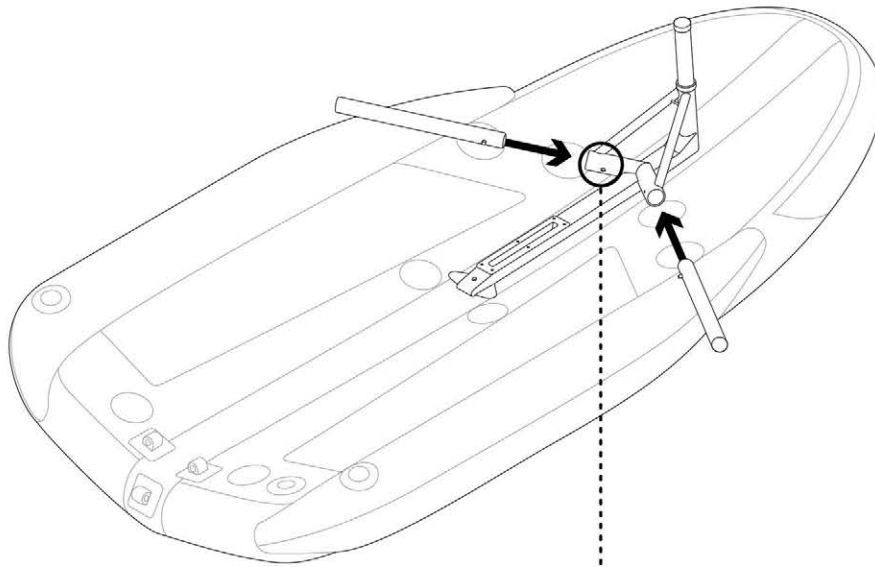

4

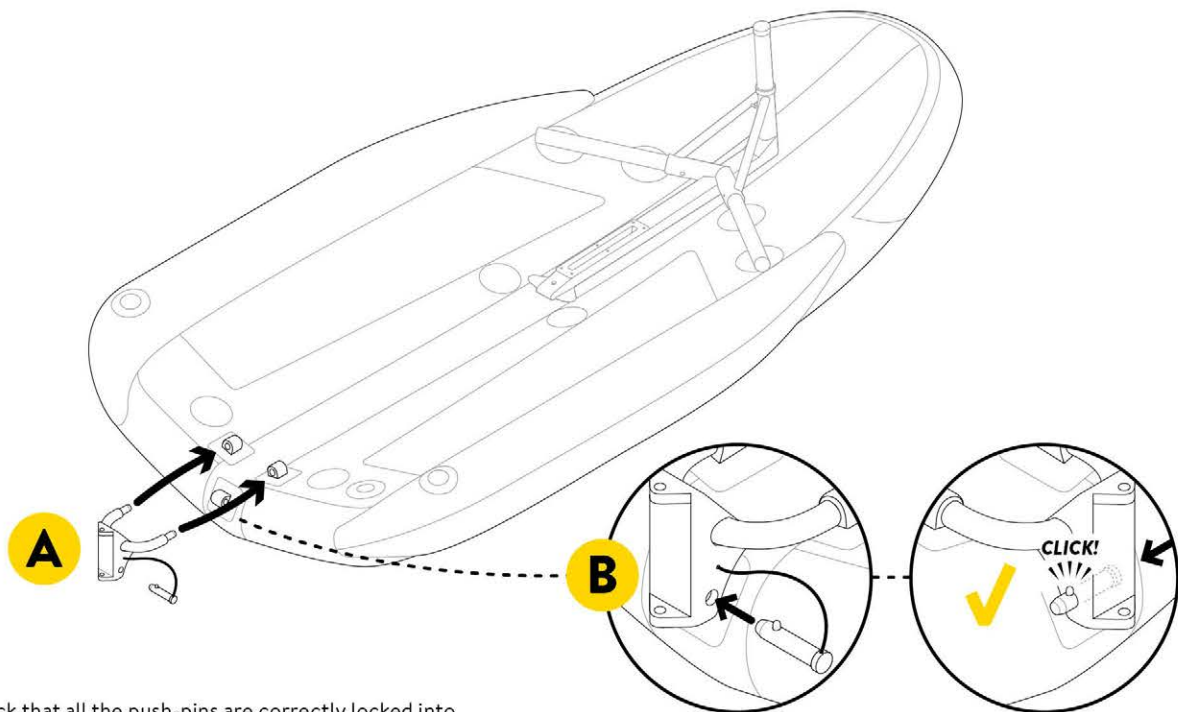

Check that all the push-pins are correctly locked into their corresponding sockets otherwise the structure could easily be damaged and you could lose some parts of the boat. Avoid sand when you assemble the boat.

5

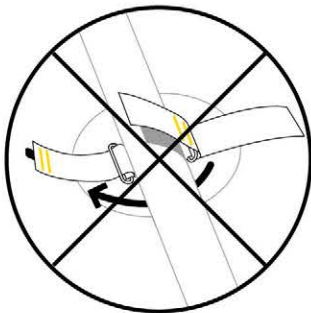
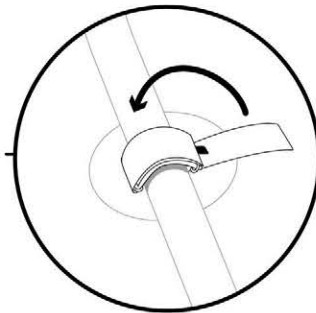
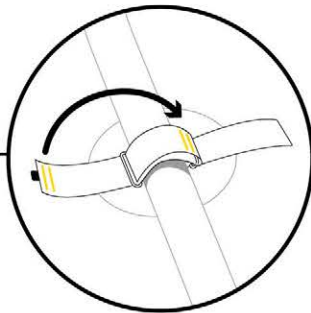
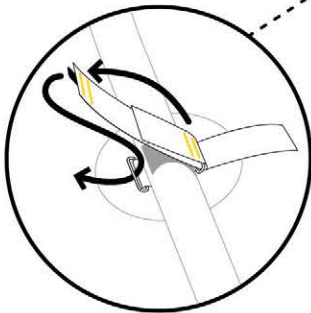
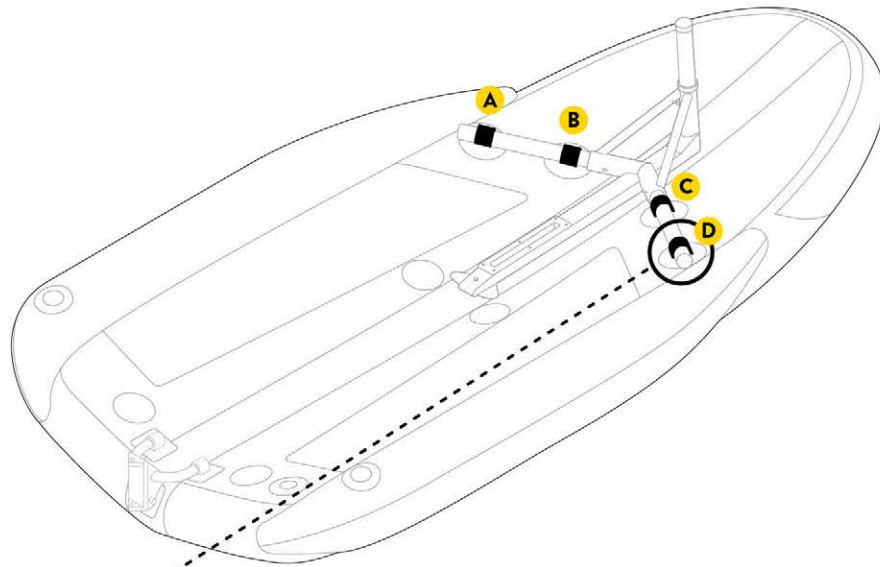

Close the straps over the tubes (never underneath) in order to secure the structure against the hull. Do not get any sand on the hook and loop straps.

6

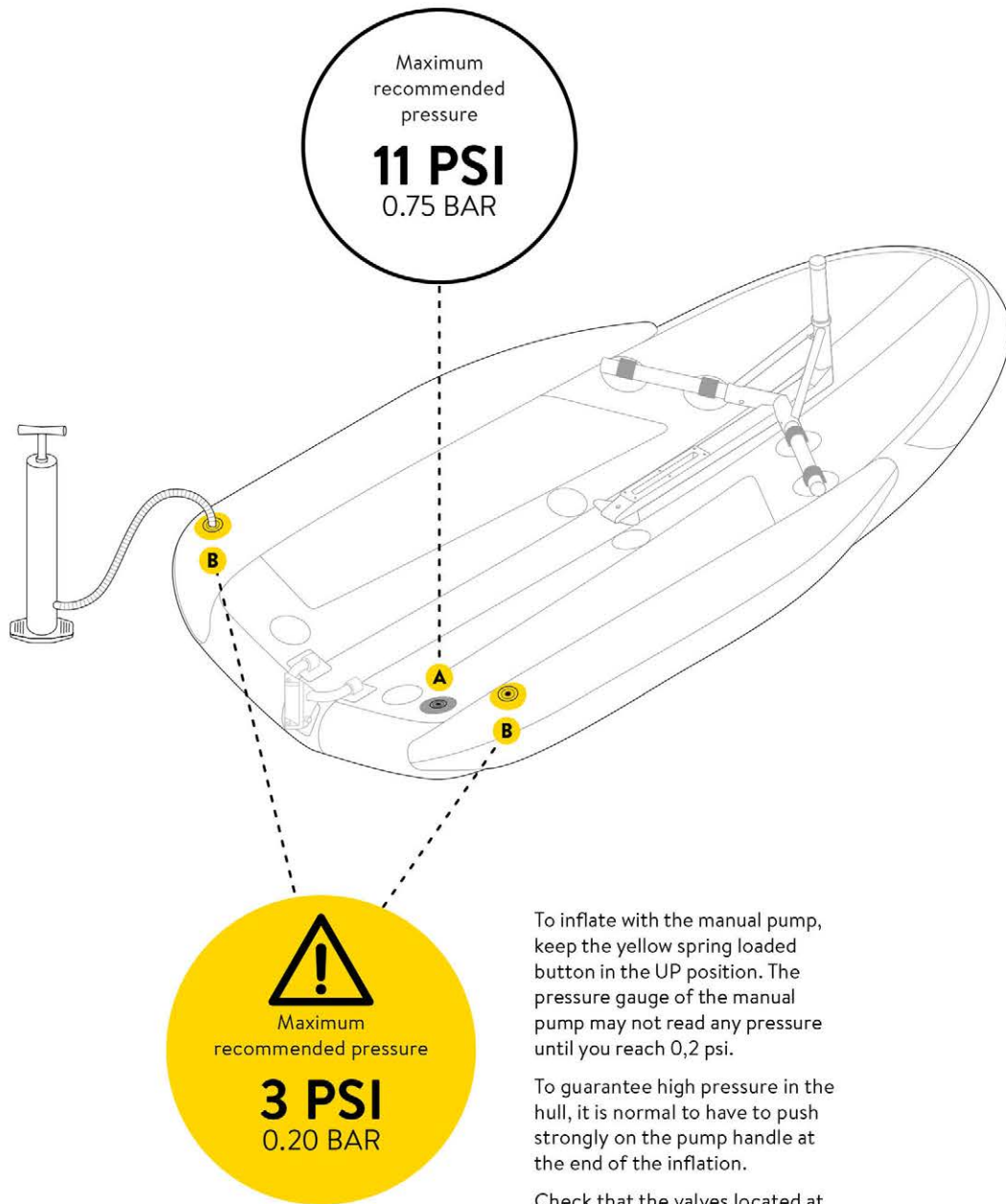

7

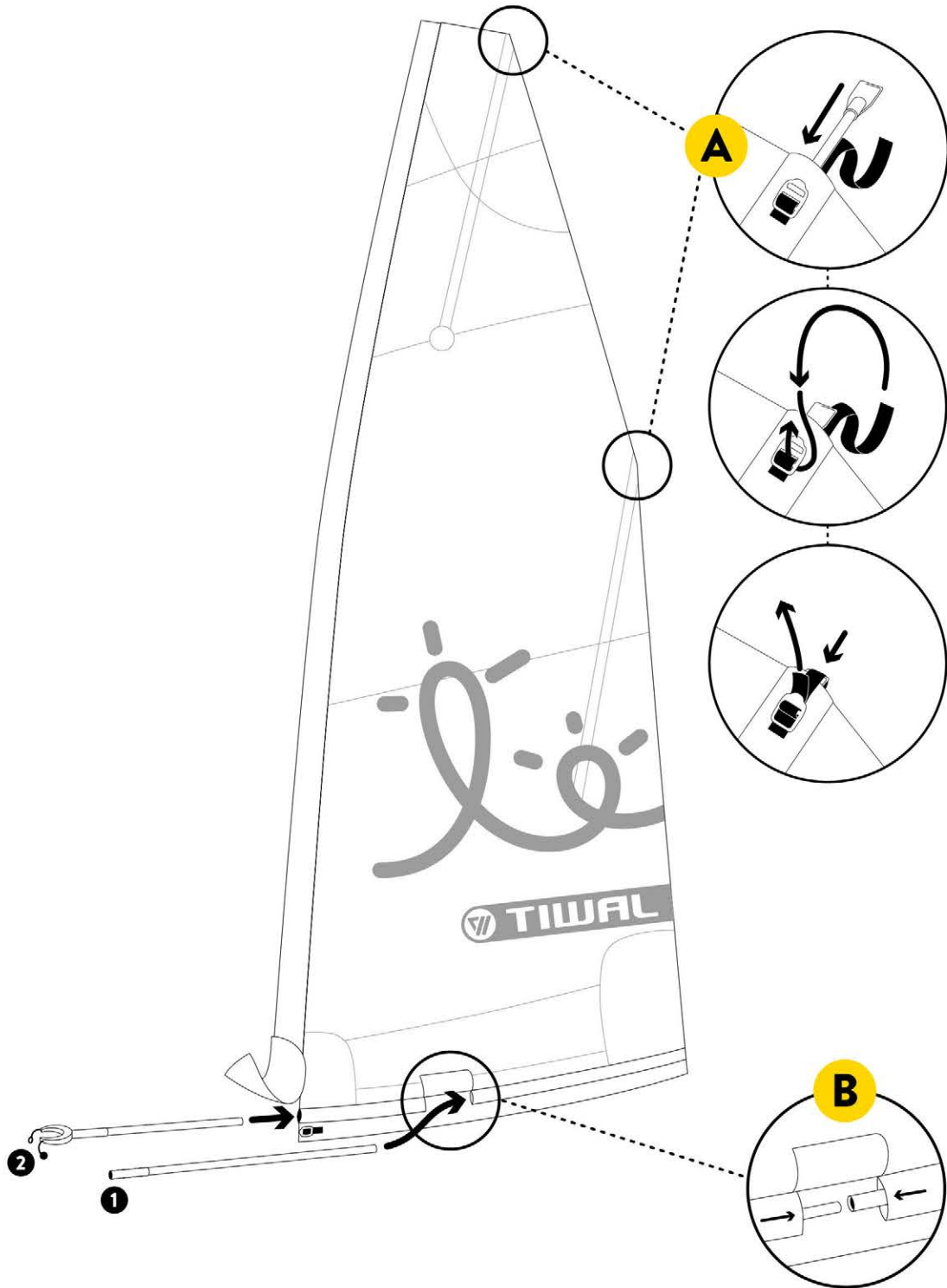

WIND (BEAUFORT)	1	2	3	4	5
60 ft ² furling sail	✓	✓	✓	✓	✗
64 ft ² reefable sail	✓	✓	✓	✗	✗
52 ft ² reefable sail	✓	✓	✓	✓	✗

8

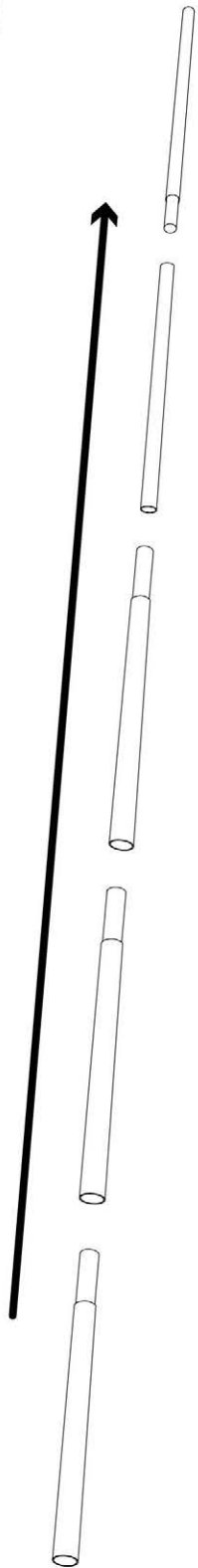

Always make sure that there is no sand on the mast or its sleeves before assembly.

9

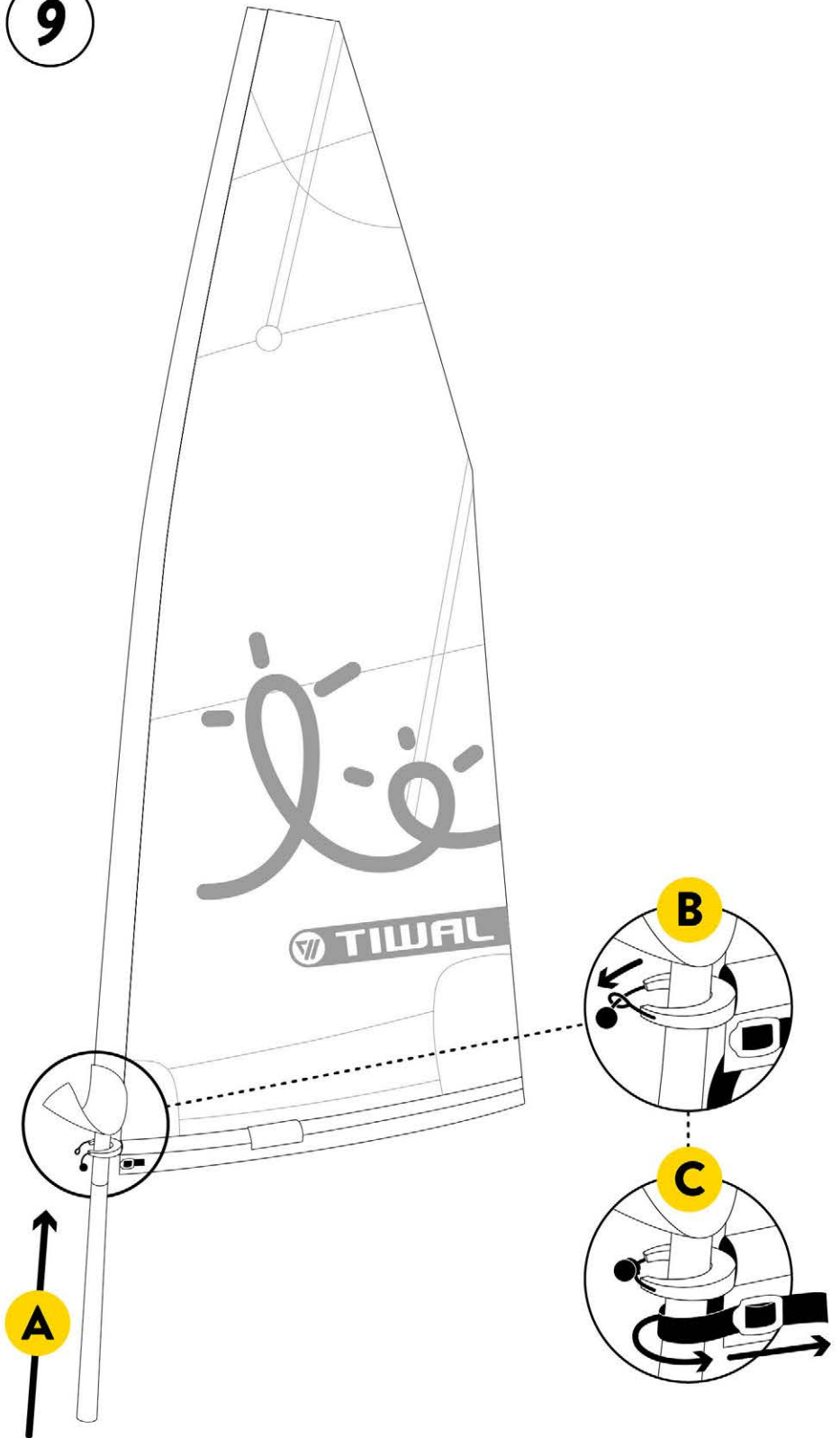

Once the mast is inserted into the luff tube of the sail, tighten the boom pocket with the hook and loop strap. Adjust the tension with the hook and loop strap so the boom is tightly held in the boom pocket while sailing.

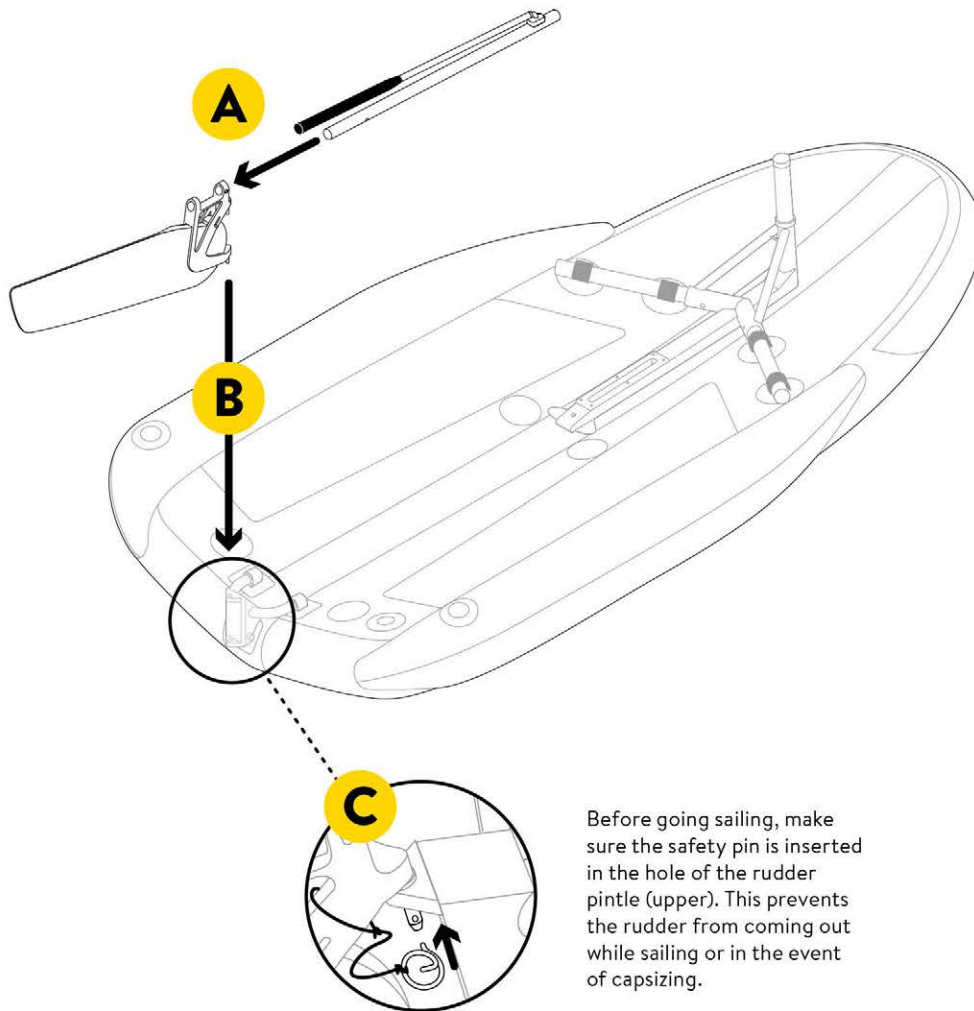
10

11

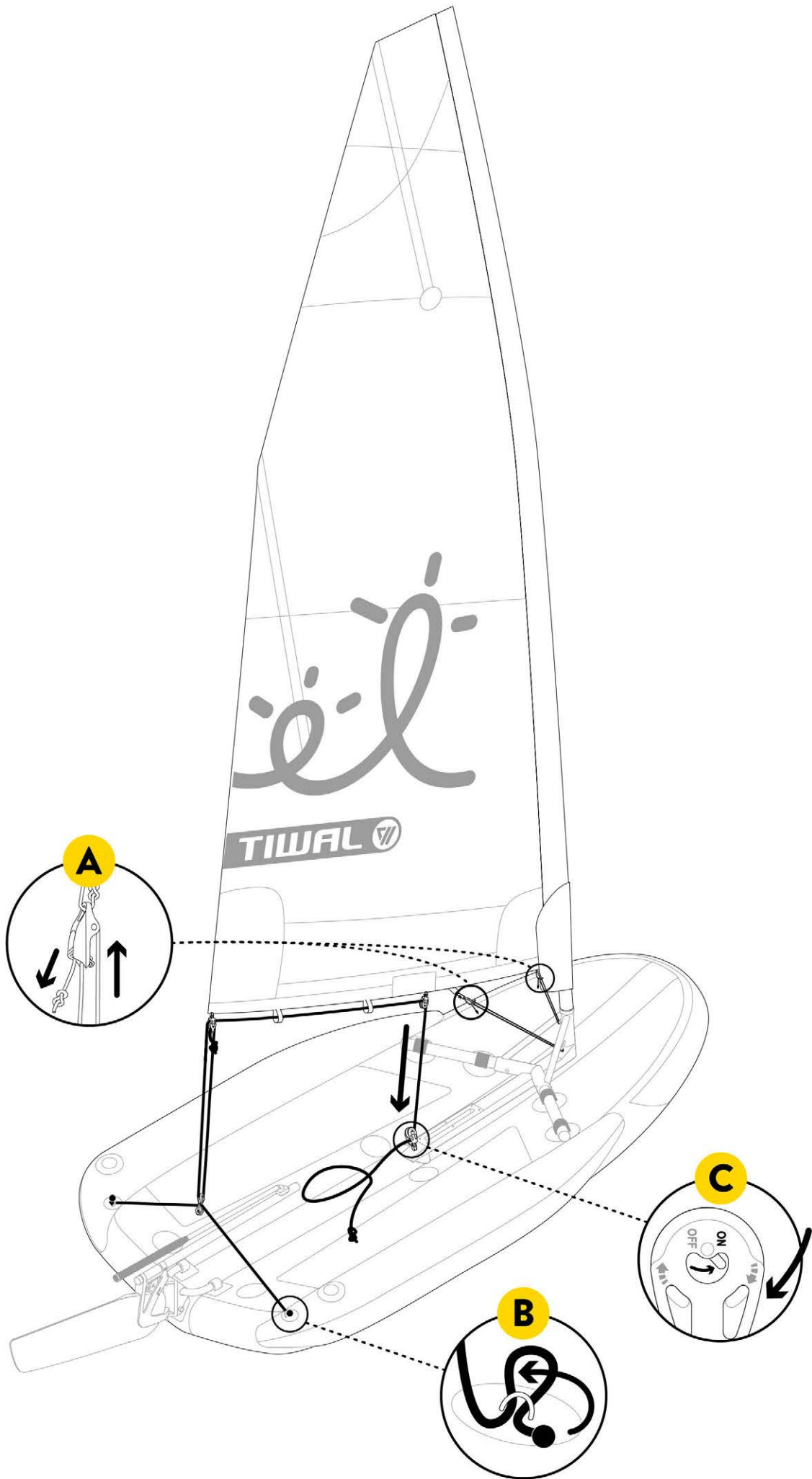

12

Method for attaching the tiller extension to the tiller

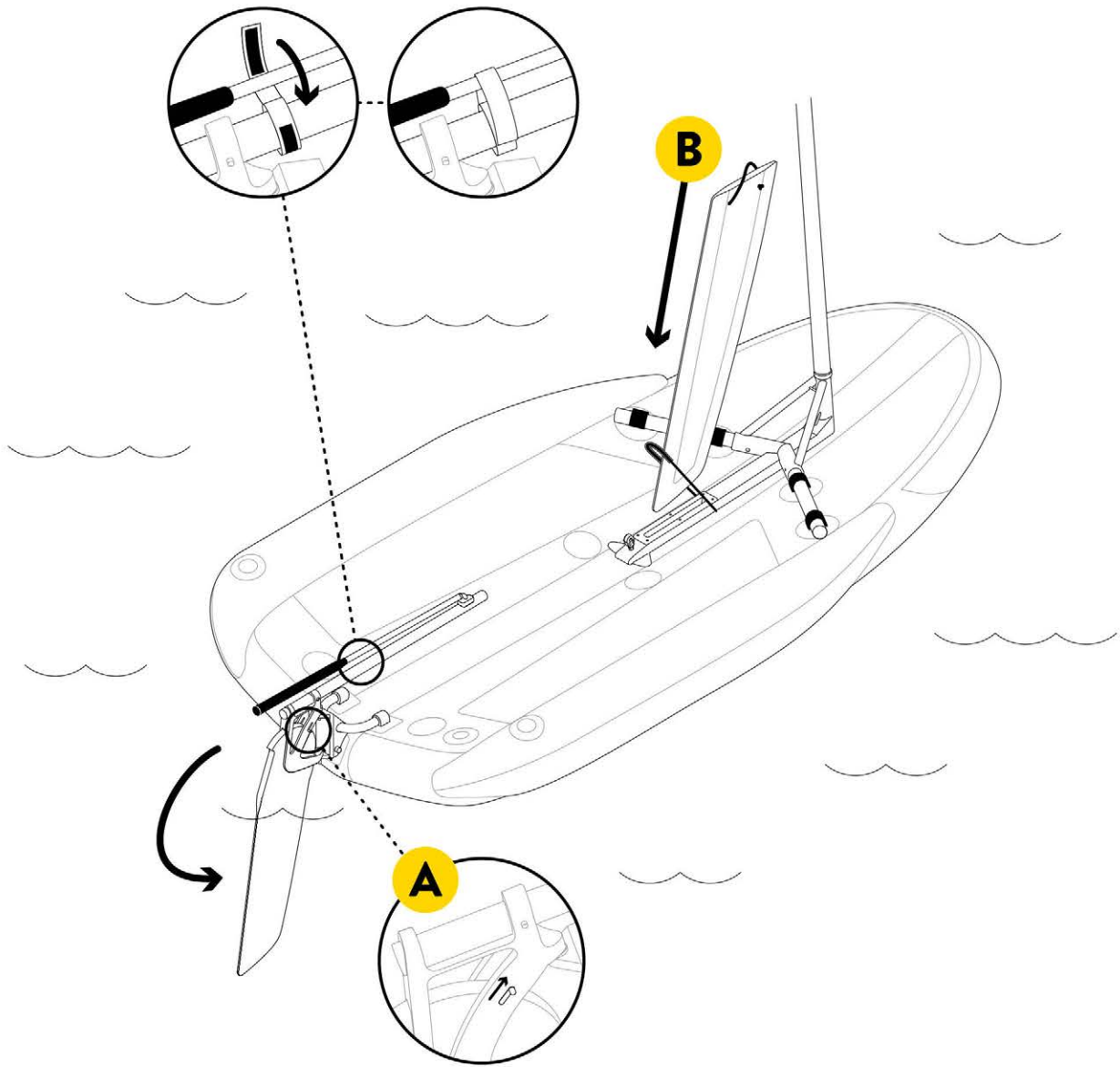

TIWAL

185 Alewife Brook Parkway - Suite 210
Cambridge MA 02138 U.S.A.

info@tiwal.com

www.tiwal.com

Our boats are manufactured under US Patent No. 9,694,875, CN Patent 103958340, EP 2 768 723

Copyright © 2023 TIWAL. All rights reserved.
Reproduction in whole or in part without written permission is prohibited.